

Hexacoif Acces MoT / MoP

Smoke vents range

NSHEV + ROOF ACCESS
Single Flap
(Mechanic or Pneumatic)

CE - This smoke vent meets the
European regulation EN 12101-2
in force.

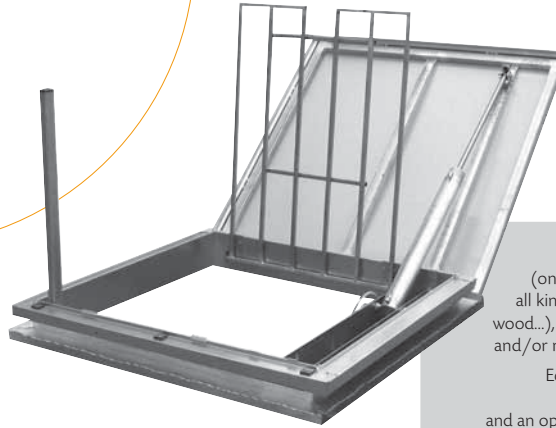

Hexacoif Acces MoT/MoP (one opening flap) is designed to fit with all kind of existing support (concrete, steel, wood...), and can be controlled by thermofuse and/or mechanic (or pneumatic) control box.

Equipped in option with a cross bar for roof access, an adaptation for ladder and an opening griddle, this skylight also allows an access to the roof in safety.

Dimensions

Performances

Characteristics

References	DT ⁽¹⁾ l x L in cm	DB ⁽¹⁾ l x L in cm	Geometrical Area (Av) in m ²	Lighting surface (SLu) in m ²	Aerodynamical Area (Aa) in m ²			Snow load / Working pressure (bar) ⁽⁴⁾								Total volume of pistons in liters (L)
								MoT				MoP				
					E (Eco)	S (Standard)	+ (Plus)	PCA ⁽²⁾	CAI/DD ⁽²⁾	PCA ⁽²⁾	CAI/DD ⁽²⁾	SL 250 ⁽³⁾	SL 500 ⁽³⁾	SL 250 ⁽³⁾	SL 500 ⁽³⁾	
C 100 straight	100 x 100	100 x 100	1,00	1,00	0,40			●	●	●	●	16	27	16	27	1,70
C 120 straight	120 x 120	120 x 120	1,44	1,44	0,58			●	●	●		13	23	13	23	2,11

(1) DT = Dimension Top of upstand (Commercial reference) and DB = Dimension Bottom of upstand (Geometrical area) - (2) PCA = Multilayer polycarbonate panels 10 or 16 mm, CAI = Insulated aluminium cover and DD = Double Dôme - (3) SL 250 (0-400 m of altitude) - SL 500 (400-800 m of altitude and more) - (4) Minimum pressure of CO₂ for closing = 8 bar (MoP only)
● Available

Hexacoif Acces MoT / MoP

Smoke vents range

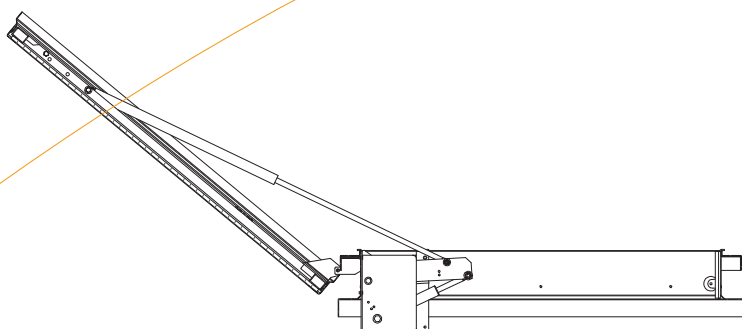

Hexacoif Acces MoT in safety position

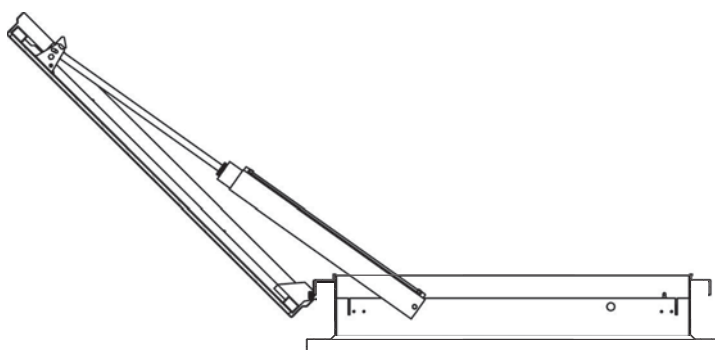

Hexacoif Acces MoP in safety position - Opening 140°

COMPONENTS:

- A metallic upstand in galvanized steel of 150 mm high, which can be installed on all kind of existing support (concrete, steel, wood...).
- This product also allows to transform the original function of an existing skylight, while conserving the existing upstand.
- An aluminium frame which protects the periphery of dome or PCA.
- A thermofuse pre-installed in the factory (in option).
- One opening flap controlled by 2 different systems:
 - Hexacoif Acces MoT:
The opening power is given by one or two air-and-oil jacks integrated in the whole system. The opening and closing function is controlled from the floor by activating a crank which causes the rolling-up of the cable.
 - Hexacoif Acces MoP:
The opening power is given by 1 CO₂ piston integrated in the whole system. The opening and closing function is controlled from the floor by activating a CO₂ cartridge for opening and a CO₂ cartridge for closing.

FILLING:

- Our standard:
 - PCA 10 mm 4 skins
- In option:
 - PCA 16 mm 7 skins
 - Double dome in PMMA, polycarbonate or Hexachoc 1200J
 - Insulated aluminium cover

For additional details, see the rubric of the options.

Working	Type B opening + closing
Cycles	Re 10,000 (daily ventilation) + Re 1,000 (smoke extraction)
Snow load	SL 250 or SL 550
Low temperature	T (-15°)
Wind load	WL 1 500 Pa
Resistance to heat	B 300 °C