

Profile LTP 45 - LINDAB

Smoke vents range

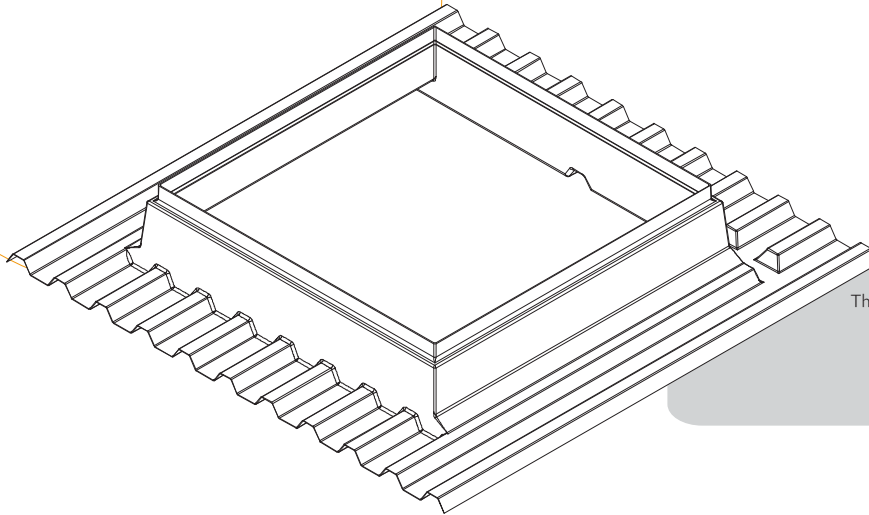

This special profile in polyester is available with:
- Hexaonde Fix
- Hexaonde Air
- Hexaonde MoP

Dimensions

Performances

Characteristics

References	Products	Geometrical Area (Av) in m ²	Aerodynamical Area (Aa) in m ²		Working pressure (bar) ⁽⁴⁾			
			Eco	Standard	SL 250 PCA	SL 550 PCA	SL 250 CAI/DD	SL 550 CAI/DD
C 120	Hexaonde Fix	1,44	–	–	–	–	–	–
C 120	Hexaonde Air	1,44	–	–	–	–	–	–
C 120	Hexaonde MoP	1,44	0,72	0,96	21	10	17	11
C 150	Hexaonde Fix	2,25	–	–	–	–	–	–
C 150	Hexaonde Air	2,25	–	–	–	–	–	–
C 150	Hexaonde MoP	2,25	1,13	1,49	15	11	10	12
120 x 170	Hexaonde Fix	2,04						
120 x 170	Hexaonde Air	2,04						
120 x 170	Hexaonde MoP	2,04	1,02	1,34	18	13	10	15
100 x 200	Hexaonde Fix	2,00	–	–	–	–	–	–
100 x 200	Hexaonde Air	2,00	–	–	–	–	–	–
100 x 200	Hexaonde MoP	2,00	1,00	1,30	21	10	17	12

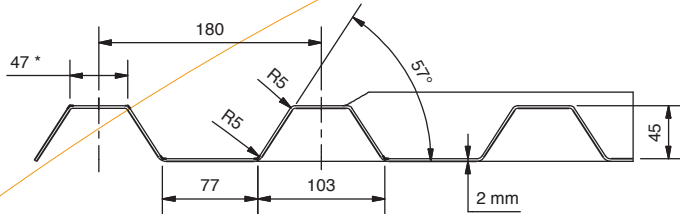

C 120

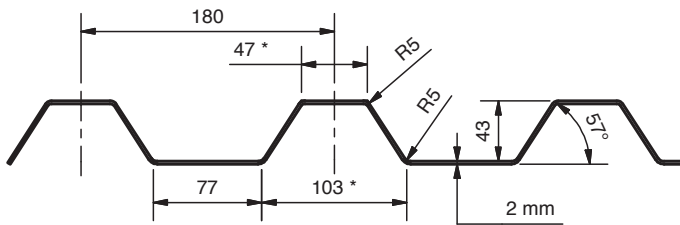

120 x 170

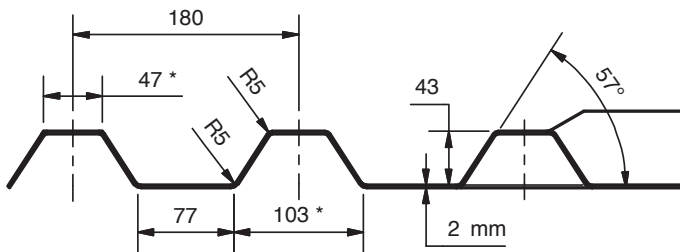

100 x 150

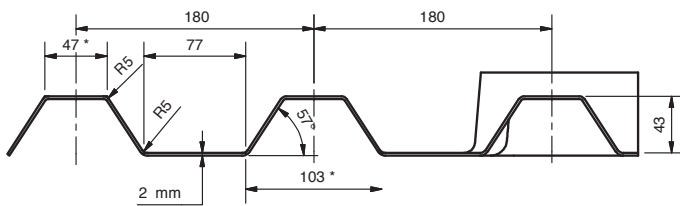

100 x 200

DESCRIPTION

A polyester upstand reinforced with tinted glass fiber, this profile is available in 3 versions:

- Hexaonde Fix which is equipped with a frame in galvanized aluminium, fixed on the polyester upstand.
- Hexaonde Air which is equipped with a frame in galvanized aluminium fixed on the polyester upstand.

This one can be controlled by different systems:

- Hexaonde Air Manual: a screw operated with the help of a crankshaft (250 mm stroke).
- Hexaonde Air Electric: with an electric drive 230V, 50Hz, 150W, 0.7A, 300 mm stroke (switch in option).
- Hexaonde Air Treuil: The opening power is given by one or two air-and-oil jacks integrated in the whole system. The opening and closing function is controlled from the floor by activating a winch which causes the rolling-up of the cable.

- Hexaonde MoP which is equipped with:
 - An aluminium frame which protects the periphery of dome or PCA.
 - A thermofuse pre-installed in the factory (in option).
 - One opening flap controlled by thermofuse and/or central pneumatic box. The opening power is given by 1 CO₂ piston integrated in the whole system. The opening and closing function is controlled from the floor by activating a CO₂ cartridge for opening and a CO₂ cartridge for closing.
 - In option, an electric drive 230V can be installed for daily ventilation purpose (opening of 30 cm).